

23614 – Mini Bridge

Assembly Instructions

Components:		Part	Name	Qty	Part	Name	Qty	Part	Name	Qty	Tools Required
		A.	Side	2	B.	Plank	10	C.	35mm Screws	40	Screwdriver

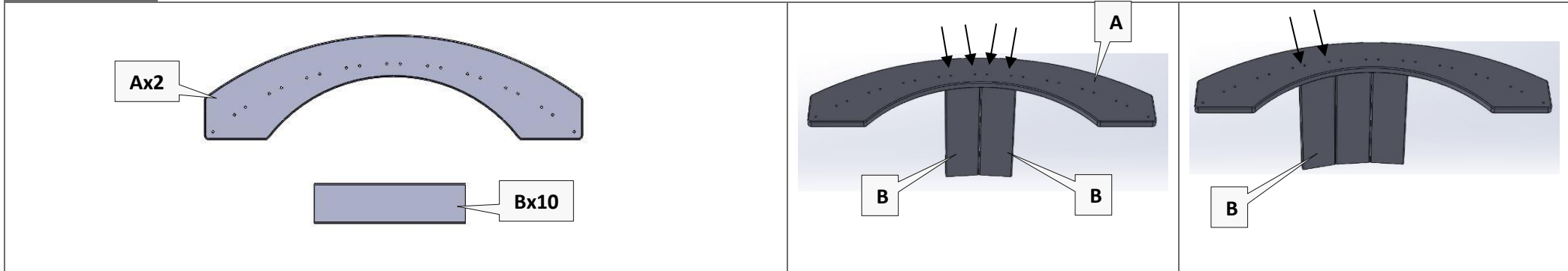

1. Check you have all the components.

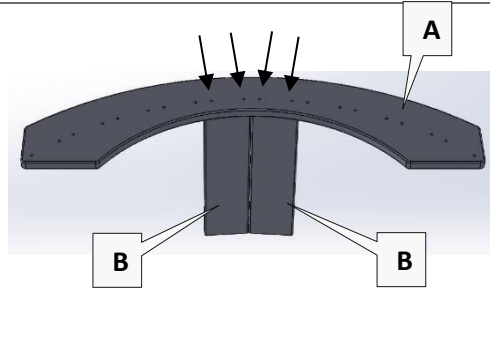

2. Position one of part A and 2x part B as shown. Fix in place using 4x 35mm screws.

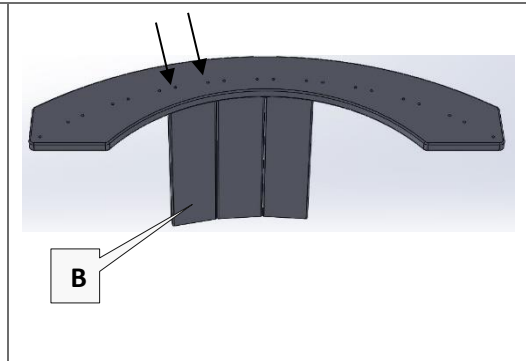

3. Position 1x part B as shown. Fix in place using 2x 35mm screws.

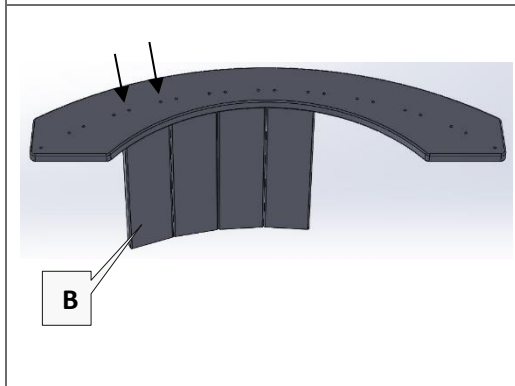

4. Position 1x part B as shown. Fix in place using 2x 35mm screws.

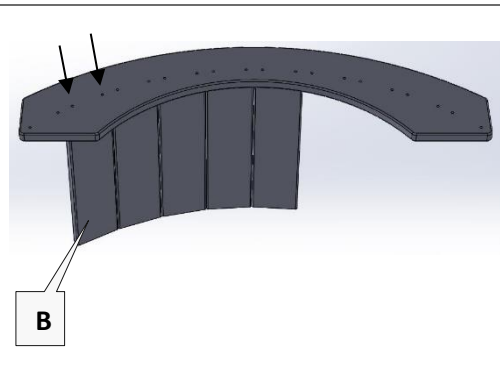

5. Position 1x part B as shown. Fix in place using 2x 35mm screws.

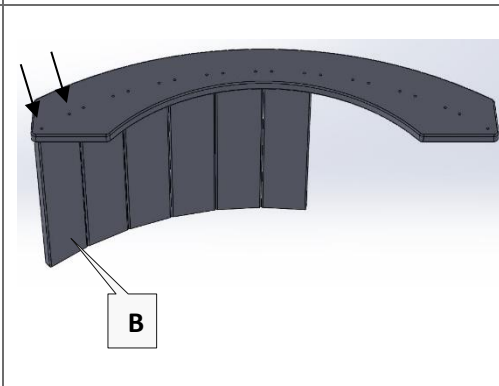

6. Position 1x part B as shown. Fix in place using 2x 35mm screws.

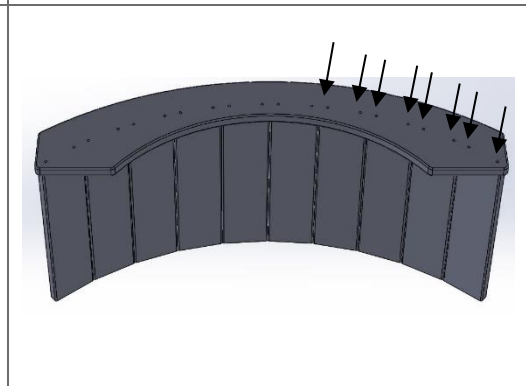

7. Repeat steps 3-6 with the remaining parts B.

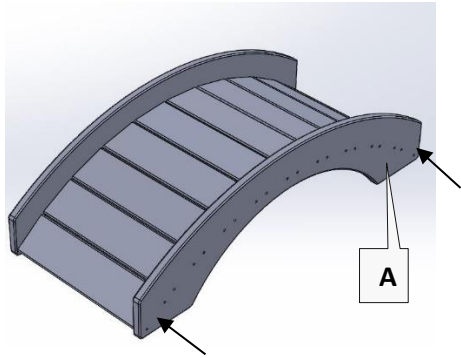

8. Position remaining part A as shown. Repeat steps 2-7, using 20x 35mm screws.



9. Done.

Email us your Bright  Ideas
ideas@cosydirect.com

Physical Development Play Equipment – Instillation & Maintenance Guide

This information is only provided as guidance. You should always satisfy yourself the product is completely safe to use in your environment with a full safety assessment.

Physical Development Play Equipment gives a variety of open ended joy, creative thinking, enabling a broad range of children to assess risks and benefits and create some wondrous, playful and memorable experiences.

Installation & Maintenance

- For safety all Physical Development Play Equipment is required to be sited on a flat level surface, with a suitable safe surface that conforms to EN 1177:2018 (Please check with your surface installation contractor)
- Adult supervision required at all times.
- Before the start of each play session check that all the fixings are tight.
- Check play equipment daily after use for breaks and hazards such as crack and splinters. (Wood is a natural product and susceptible to splitting due to damp & dry conditions) Record and report any permanent defects.
- Report any safety problems to COSY immediately.
- If any parts become damaged or broken it must be reported to COSY immediately.
- Any spare parts must be ordered from COSY.
- The treatment on the play equipment MUST be re-applied 6-12 months to help prolong its life.
- Please be sure that any stains or paints used are child-friendly and non-toxic.

Free Fall Heights

- All climbing products with a height up to 150cm require a free fall space of 150cm on all sides clear of any obstacles.
- All climbing products with a height up to 200cm require a free fall space of 183cm on all sides clear of any obstacles.

During Play

- Point out obvious specific risks relating to individual products and rules of use.
- Identify which products may need higher levels of supervision and store them in an area to be treated differently.
- If you are using outdoor products be aware that the risk will increase relating to certain weathers such as increased slippiness, manage accordingly.
- Physical development play equipment like all products offer opportunities that children will play in unusual ways with products, be sure to create a framework of understanding with regards to climbing, balancing, building to ensure the children play safely.
- Inform the participants that as some items are heavier or long, they should not be carried or held above head height and that some should ideally be moved using two people to ensure that no injuries occur.
- Ensure an adequate level of supervision and skill of supervisor is risk awareness trained.

Managing risk generally

Managing risk in play provision.

As with any new piece of equipment or new children using existing equipment, a risk benefit assessment needs to be undertaken and rules for use clearly communicated to ensure maximum fun in the safest way.

Source:- playengland.org.uk, & creative star

Guidance, which is endorsed by the Health and Safety Executive, shows how current risk-assessment practice takes into account the benefits to children and young people of challenging play experiences, including the risks.

It starts from the position that, while outside expertise and advice are valuable, the ultimate responsibility for making decisions rests with the provider.

The full implementation guide is written for those responsible for managing play provision, and for those involved in designing and maintaining such provision.

The general approach should also be useful for those who manage other spaces and settings where children play.

To download Managing risk in play provision: Implementation Guide, visit

www.playengland.org.uk/managingrisk